

SECTION 1-1

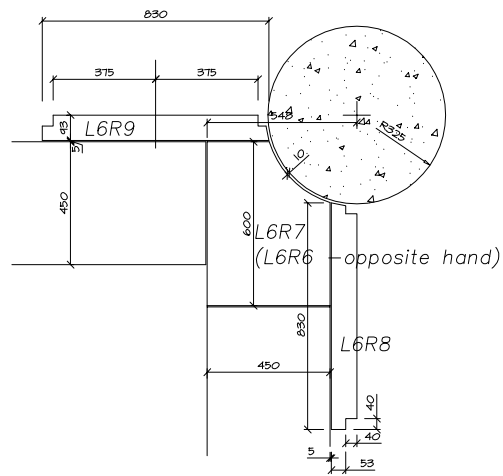

DETAIL D1

Rev.	Date.	Comments.
b	10.10.00	Stone mark numbers amended.
a	4.10.00	Stone identification marks added.

Key Plan

stewart design (uk) ltd
 3 clarendon court, park street, charlbury
 chipping norton, oxon, uk, OX7 3PT
 tel: +44 (0) 1608 811500 fax: +44 (0) 1608 811700
 e-mail: design@stewarddesign.co.uk

S

Contract Title: Tiffany Museum Mataue Japan	Drawing Title: Stone Details. Performance Area. Sections & Details.	Scale: 1:10 @ A1
Architects: -	Contract no: -	Date: 15/09/00
Clients: Johnsons Wellfield Quarries Ltd	Origin Drawing ref: -	Drawn: T.Abbott.
		Drawing No: GA007
		Rev. b